

Receiving Guide

How to send products to any Shipwire-enabled fulfillment center

What's inside

Introduction	03
Before You Ship: Checklist	04
Preparing Your Shipment	05
Packaging	06
Labeling	09
Special Products	12
Shipping to a Fulfillment Center	15
Transportation Mode & Carrier Selection	16
Appointment Scheduling	18
Inbound Receiving by location	18
Additional Info	22

Introduction

Receiving provides the foundation for all other fulfillment center activities. In order to provide the best experience for your brand, Shipwire utilizes a methodical, repeatable and scalable receiving process. This allows the inbound operation to pre-assign storage locations, make better use of resources and move inventory as efficiently as possible. By following this guide, you will help our operations team meet service levels for your receipts, ship to your end customers faster and avoid unnecessary charges, errors or delays.

Who is this Receiving Guide intended for?

Operations
Managers

Business Owners
General Managers

Customer Support Managers
Personel



Before You Ship: Checklist

Follow this checklist to make sure your receipts follow our Standard Receiving Guidelines. Unqualified receipts that do not follow the guidelines can incur additional fees and are likely to take longer to be processed and inventoried.

If you have further questions, contact us at <https://www.shipwire.com/customer-support/> or reach us by phone at **888-SHIPWIRE**.

Your checklist

- Create a Receiving Order (ASN).
- Ensure receiving will arrive with tracking or Bill of Lading (BOL) information.
- Properly label and package pallets, master cases, inner packs and base product units.
- Products and product counts in receiving must match those listed on the Receiving Order.
- Inventory must arrive free and clear of customs, duties and tariffs, with correct Importer of Record and Tax ID information.
- Inventory arrives at warehouse at the prescheduled appointment date/time (varies based on location requirements).



Preparing Your Shipment

Getting ready to send your inventory to Shipwire fulfillment centers

Packaging

To help you minimize cost and prevent unnecessary errors and damage, Shipwire offers specific guidelines for packaging inventory. All shipments will require a master packing list.

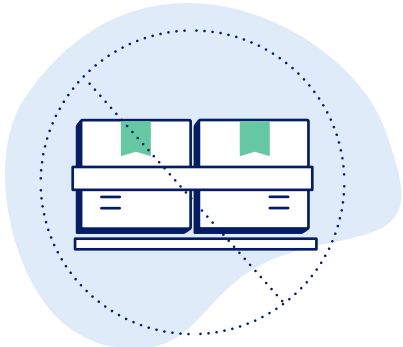

Important packaging instructions

- Do not shrink wrap, strap, tape or bind boxes together
- If shipping on a pallet, do not allow boxes to overhang pallet by more than 1 inch (2.5 cm)
- All pallets must be shrink wrapped
- Do not use any type of packing peanuts, crinkle wrap or shredded paper

Packaging master cases using cartons

Cartons are protective packaging used during inbound transit and receiving. Carton requirements are as follows:

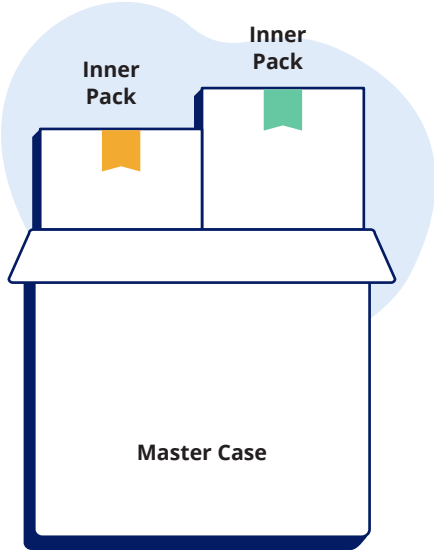

If contents <70 lbs. (31.75kg), must use double-wall corrugate.
If contents >70 lbs. (31.75kg), must use triple-wall corrugate.
Must score a minimum of 200 lb. on the bursting strength* test and 32 on the edge crush test.*

All shipments will require a master packing list

**The ability of a carton to withstand pressure is measured by two tests. The bursting strength test measures the force required to rupture or puncture the face of corrugated cardboard and the edge crush test measures the ability of a carton to withstand the pressure of stacking.*

Packaging oversized and heavy items

Cartons or individual items greater than 18 in (45.7 cm) in any two measurements (e.g. length and width), and/or with weight greater than 28 lbs (12.7 kg), are considered oversized.

Oversized cartons or items should be sufficiently packed to withstand pressure incurred during handling. They should be able to sustain being moved or handled with equipment including, but not limited to:

forklifts, pallet jacks, clamp trucks, conveyors, hand trucks and sortation equipment.

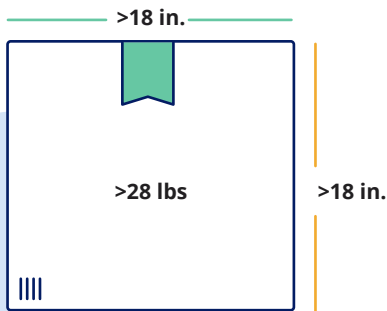

Oversized items may incur additional receiving charges. Please contact our customer success team if you have any concerns or questions about your product.

Polybags and soft inner packaging

Soft packaging (e.g. plastic polybags) should be used as protection during shipment. Polybags can be used to protect products (e.g. apparel) during storage and outbound shipping to customers. We recommend following these packaging tips:

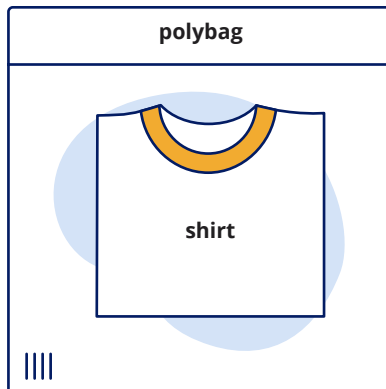

- If individual units are not stored inside cases, they should not be exposed in their display boxes. If there is an opening that shows the contents of a package, it should be shielded by clear plastic to protect the product from dust.
- For apparel, use low-density, recyclable, polyethylene dry cleaning-style bags at least 1 mm in thickness. Contents should be easy to remove from these bags.
- Plastic bags must comply with all federal, state and local laws.
- Include a silica gel pack if your product is sensitive to moisture.
- To ensure that any packaging used for toys is not hazardous to children, do not package toys in bags that stretch to more than 14 in (35.5 cm) in neck circumference, or to more than 23 in (58.4 cm) when the stretched neck circumference and the bag's length are combined.

[Find more information about packaging in our online Support Center.](#)

Fragile Products

Products or retail packaging susceptible to damage through ordinary handling, shipping or extended storage must be packaged so that they are strong enough to pass a 4 foot (1.2 m) drop test on a hard surface. Passing this test indicates that your products will be able to withstand typical impacts during shipping and handling without breaking. A typical drop test consists of five drops.

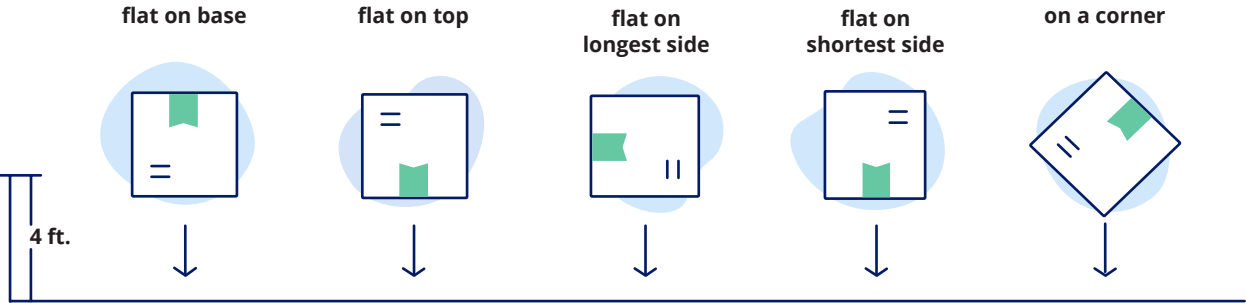

If your packaging can protect your product during these tests, it has passed the 4 foot drop test. Products must also be able to withstand a full minute vigorous shaking test without any of the contents breaking.

Defining fragile products

When creating a product in your Shipwire Platform account, you must indicate fragile products accordingly.

Packaging fragile products

When shipping glass, breakable or sharp items, bubble wrap should be used so the product will not break and create a potential safety hazard during storage, handling or shipment to the customer. Do not use any type of packing peanuts, crinkle paper or shredded paper.

Hazmat products

For any products deemed as Hazardous Materials, such as lithium ion batteries, flammable products, lighters, nail polish, hand sanitizer, aerosol cans and other products. These products have specific receiving, storage and shipping requirements. Please contact us at <https://www.shipwire.com/customer-support/> or reach us by phone at 1-888-SHIPWIRE to understand the requirements in shipping those specific products. See our [support page](#) for more information about shipping lithium batteries.

If the product is fragile or glass:

Place or wrap the unit in protective bubble wrap or a protective overpack. The unit must be able to pass a drop test on a hard surface without breaking. Ensure barcode is scannable without opening or unwrapping the unit.

If the product is sharp:

Place or wrap the unit in protective bubble wrap or protective overpack so that the packaging completely covers any exposed edges. Ensure barcode is scannable without opening or unwrapping the unit.

Labeling

Labeling your product correctly is one of the single most important steps to start off your product's lifecycle in our facilities. Follow these guidelines to prevent unnecessary errors, delays and fees. We require that all shipments have an ASN label and that all master cases, inner packs and base products are labeled with barcodes and base unit quantities.

Any inbound shipments that do not comply with our labeling requirements will be subject to fees.

ASN Labels

If you are sending pallets, ensure that each pallet has an Advanced Shipping Notice (ASN) label attached (preferably on each side of the pallet). If you are shipping unpalletized master cases, please sure to include an ASN label on each master case. When you create an ASN in the Shipwire Platform, you're provided an ASN shipping label and packing list as a PDF for your convenience. Should you create your own ASN labels, please include the following information:

ASN Number: The Advanced Shipping Notice number generated by the Shipwire Platform when you create your Receiving Order.

Pallet Qty: The pallet number plus the total number of pallets in the shipment (e.g., Pallet 1 of 4). If your shipment is not palletized, please indicate the number of master cases (e.g., Master Case 1 of 4).

From Address: Your company name and address.

To Address: The warehouse destination address. Reference pages 18 - 22 for shipping information and delivery appointment scheduling.

ASN labels must follow these guidelines:

- Label must be white
- Minimum font size of 12 pt
- Minimum label size: 4 in x 6 in (10 cm x 15 cm)
- Include a packing list with every inbound shipment

Product Labels

Products must be labeled with the *base product's* scannable barcode and quantity of product contained at each level of packaging (pallet, master case, inner pack and base products). Compliant labeling allows our operations team to quickly determine the contents and quantity in each shipment, without needing to open master cases or inner packs. While the Shipwire Catalog defines master case and inner pack level SKUs in terms of visibility, labels for all master cases and inner packs must accurately physically reflect the *base product's* scannable barcode and product quantity.

Product labels must follow these guidelines:

- Label must be a scannable barcode of the base product
- Label must be white
- Minimum font size: 12pt.
- Minimum label size: 1 in x 0.25 in (2.5 cm x 0.6 cm)
- Whitespace: 0.2 cm white space around border of label

Proper Labeling Example:

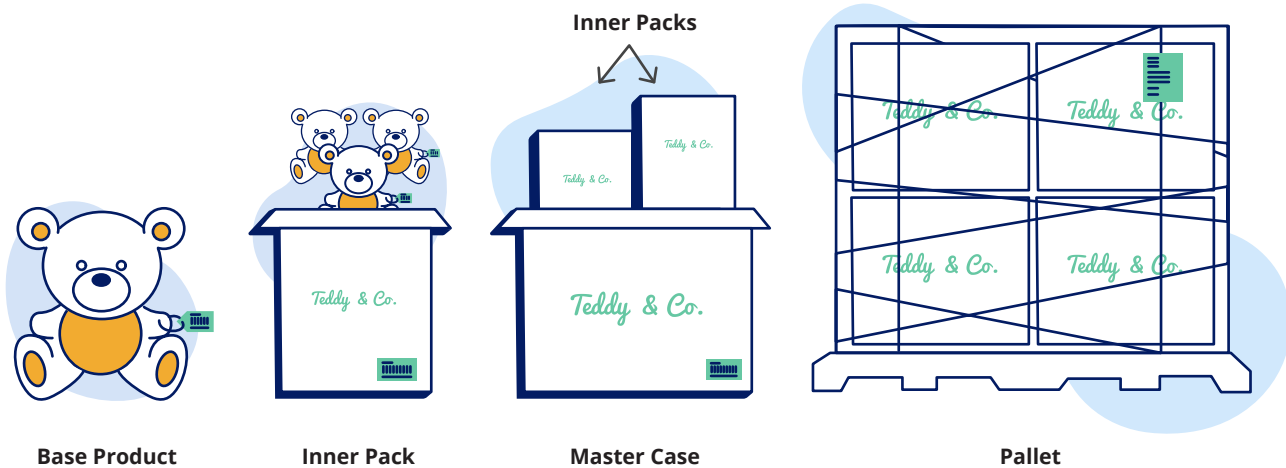

Pallet

The pallet has an ASN label, which includes the ship to/from addresses, ASN number and pallet number (e.g., pallet 1 of 4).

Note, if shipping unpalletized, each master case will need its own ASN label with this information.

To: Shipwire
12510 Micro Drive
Mira Loma, CA 91752

From: Teddy & Co.
7069 W.Hillcrest Street
Rahway, NJ 07065

ASN: 886521

Pallet 1 of 4

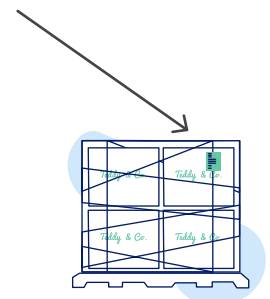

Master Case

The master case is labeled with the base product's scannable barcode (in this example, the single teddy barcode) and indicates the quantity of single teddys inside. You do not need to indicate the quantity of inner packs, just the total quantity of base products.



Inner Pack

The inner pack is labeled with the base product's scannable barcode (e.g., the single teddy barcode) and notes the quantity of single teddies inside.

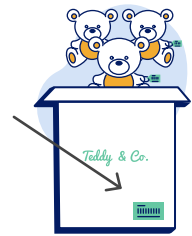

Base Product

The base product is labeled with its scannable barcode



Accepted Scannable Barcodes

Preferred labeling method



Scannable UPC barcode

Other accepted barcodes



Scannable VPN (vendor part number) barcode:



Scannable SKU name barcode

You can create the barcode labels yourself or use the label tool in the Shipwire Platform. To access the label generator, log into your Shipwire account and go to [Product Catalog > Select Product > Download Label](#). Be sure to download the base product label and use that for labeling your master case and inner pack boxes as described in the guidelines. Labels must be printed on adhesive label stock. You cannot print on plain paper and use adhesive label envelopes or clear tape to attach them.

Special Products

Mixed Products

When you send products, you should not have more than one product type (SKUs) on a pallet, in master cases or in inner packs. If products are mixed, we'll need to break down the shipment and you will incur fees.

Example: If a pallet contains 6 master cases of blue cameras, it meets packing standards. The entire pallet has only has blue cameras and there are no master cases or inner packs with red, yellow, or green cameras on the pallet.

Small Products

If your item is too small for a label, it should be placed inside a polybag or a box large enough for a 2x1 inch barcode label. For example, if the product is a microchip, each microchip must be placed in a polybag and labeled with a 2x1 inch scannable barcode.

Internationally Shipped Products

International orders shipped from an Shipwire facility to customers in a different country require additional paperwork to meet trade compliance. It is required that any product (SKUs) shipping on international orders have a valid HTS number and ECCN code defined in the product catalog as to avoid orders being placed on hold. Please be sure to update the HTS and ECCN fields for each of your SKUs you intend to export in your product catalog. For more information, please visit our [Trade Compliance support page](#).

Dangerous Products

To ensure safety and compliance, we have outlined regulations on the inbound and outbound shipment of potentially hazardous products.

Please review the [Acceptable Use Policy support page](#) for more information.

Non-Compliant Inbound Shipments

A streamlined inbound receiving process allows our operations teams to be as efficient as possible throughout your product's lifecycle. Compliant inbound shipments help our teams to make better use of resources, meet service levels and ship to your end customers quickly. Please review these common inbound shipping mistakes to avoid unnecessary charges, errors and delays. Please review the [Shipwire Terms of Conditions](#) for related fees associated with non-compliant inbound shipments.

Missing or non-compliant ASN Labels: When an inbound delivery arrives at one of our warehouses we need to be able to tie it back to your inventory in the Shipwire Platform using the ASN number. Each delivery, from small parcel to palletized, needs to arrive clearly marked with the associated ASN number. See page 10 for additional ASN Labeling requirements.

Missing or non-compliant Product Labels: Whether you're shipping master cases, inner packs or base products, all your products must be labeled with a scannable barcode product label. At each layer of your packaging, our operations team needs to be able to quickly determine the exact content and quantity without having to open the item. Please see page 9 for additional Product Labeling requirements.

Floor Loaded Containers: While it may seem a better use of space to send boxes loose instead of palletizing your goods, the tradeoff is additional fees to reconfigure your shipment and potential wait fees assessed by the driver delivering the shipments.

Discrepant Product: Help us help you to maintain inventory accuracy. Ensure that your outbound inventory matches the ASN information in Shipwire and that labeling complies with our standards. Follow the guidelines to avoid fees to count quantity and/or correct product discrepancies.

Mixed SKU master cases and/or pallets: To facilitate the receiving process and ensure accurate inventory management and outbound fulfillment, we cannot accept mixed master cases or inner packs. A pallet must have master cases that contain only a single product. It is labor intensive to break down and sort mixed SKU master cases and inner packs; should this be necessary it will result in delays and fees.

Mis-packaged Product: To protect your inventory, we have strict regulations on how your product must be packaged to ensure proper handling and safe storage. We require specific pallet dimensions by location, and all pallets must be shrink-wrapped to ensure load integrity and stability during transit. See page 6 for details on how to package your inbound shipments.

Small Parcel Delivery: Small Parcel deliveries will incur a per case fee. If the small parcel delivery is of mixed SKUs, there will be a deassortment fee per unit.



Remember

- Every pallet (or master case if you aren't shipping pallets) must have an [ASN label](#).
- Mixed pallet and mixed master case shipments are non-compliant and will incur fees at receiving.
- Every master case, inner pack and base product **MUST** have the base product's scannable barcode, as well as, the quality of the base products at each packing level.
- If product arrives without proper labeling expect delays and fees



Sending Your Shipment

Shipping inventory to an Shipwire fulfillment center

Shipping to a Fulfillment Center

Use your preferred carrier to send inventory to Shipwire fulfillment centers. When you complete a Receiving Order in your Shipwire account, you will receive an email confirmation with an attachment containing a PDF of the shipping label.

Providing tracking numbers

After you ship your inventory and receive a tracking number from your carrier, enter it in your Shipwire Platform account. You can enter the tracking or Bill of Lading (BOL) information in the Receiving Details section of your account.

Accepted	Pending Delivery	Warehouse processing	Ready for shipment
2017-08-23 11:15	ETA: 2017-08-26 Expecting 1 shipment Tracking:	Typical: 3 business days Expected: 2-10 bus. days Special project: Yes	Estimated: 2018-02-20 - 2018-02-30

- Send your inventory**
Download receiving documents
We have already sent you an email with these documents. Click above to initiate download or email me again.
- Tracking Information (ID# 1503512132) edit**
Warehouse: Mira Loma, CA
Estimated arrival: 2017-08-26
Available to ship: 2017-09-05 to 2017-09-15
Tracking #: 123456
Carrier name: FedEx
Status: Pending
- Packing List**

SKU	Description	Expected	Good	Damaged
00Xin0Master	oijf	1000		0

What is a BOL?

A Bill of Lading (BOL) is a legal document between the shipper of a product and the carrier. It details the type, quantity and destination of the product being shipped. The BOL also serves as a receipt of shipment when your products are delivered.

If you do not have a tracking number when you ship inventory, you can enter it later. To do so, find the ASN in your Shipwire Platform account and edit the Receiving Details section. All inventory sent to Shipwire must have valid tracking included at least three days before scheduled arrival. Inventory that arrives to the warehouse without a valid ASN is subject to be turned away. Please see the locations details section of this guide to learn more about scheduling an ASN delivery.

Transportation Mode and Carrier Selection

A “shipment” is defined as all packages shipped from one location on one day to a single Shipwire facility. Incorrect mode selection and failure to consolidate freight collected shipments are subject to non-compliance charges.

Mode Decision Matrix - Small Parcel or LTL/TL

Shipment Size	Less than 14 Cartons	Greater than or equal to 14 Cartons
Less than or equal to Small Parcel Max Weight	Send Small Parcel	Send LTL
Great than Small Parcel Max Weight	Send LTL or HWA or TL	Send LTL or HWA or TL

Mode Decision Matrix - LTL or TL

Shipment Size	Less than or equal to Pallet Max	Greater than LTL Pallet Max
Greater than Small Parcel Max Weight	Send LTL	Send TL
Less than or equal to LTL Max Weight		
Great than Small Parcel Max Weight	Send LTL or HWA or TL	Send LTL or HWA or TL

Small Parcel Shipments

- Appropriate markings on each carton
- Properly packaged to avoid damage
- Reference the Shipwire ASN # in the correct manifest field:
 - For UPS: Package Reference No. 1
 - For FedEx: ASN Reference

LTL or TL Shipments

- Palletized shipments must be shipped on 40 in x 48 in - GMA grade A or B pallets
 - Corner boards and proper shrink wrap must be used
 - Appropriate markings on each carton and pallet as well as pallet build requirements
 - UPC/Barcode
 - Properly packaged
 - Properly shrink wrapped
 - No overhang
- The Shipwire ASN # should be included on the BOL

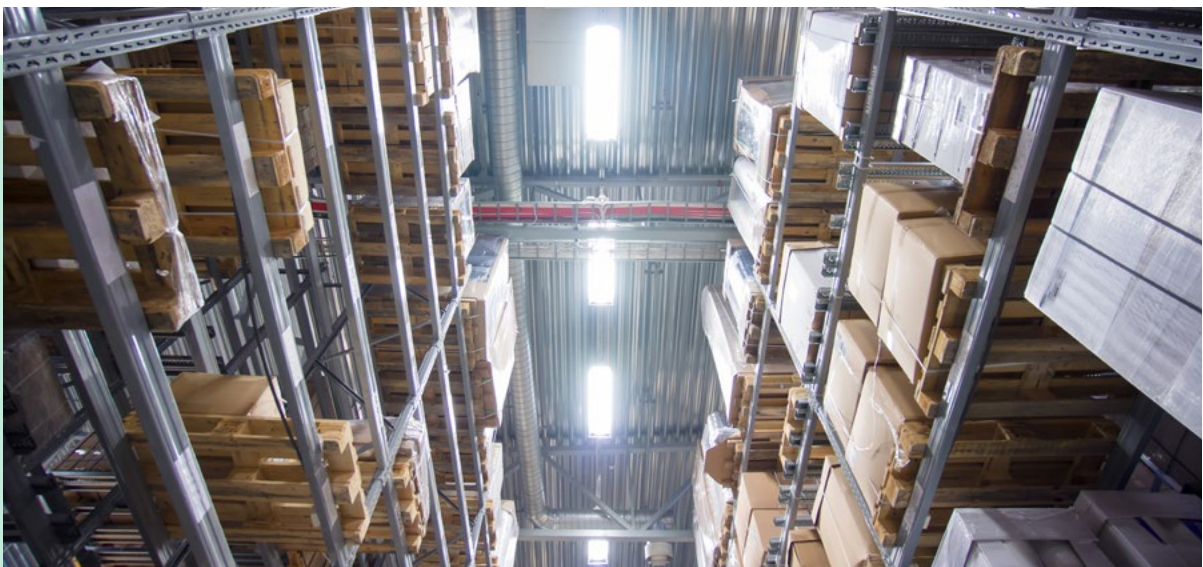

Appointment Scheduling

When sending shipments, please note specifics around scheduling an appointment based on the location you are shipping to. Each location varies, so review the information below to understand requirements, forms and any additional information needed for scheduling a delivery.

Appointment and Scheduling Details

- Appointments are only held for 15-30 minutes, site dependent. A new appointment will be required should an appointment be missed.
- Hazardous Materials must be noted prior to delivery appointment being scheduled
- Dangerous Goods must be noted prior to delivery appointment being scheduled.
These include:
 - Damages
 - Tampered packages
 - Unsafe loads
- If any portion of the shipment (ASN/PO) will be unavailable on the ship date, please call or email us ahead of time.
- Any floor loaded containers also require appointments following the appointment scheduling process by facility below. They are considered non-compliant and will incur fees.

U.S.

All drivers conducting pickups or deliveries to North American Shipwire facilities are required to present their current, unexpired drivers licenses.

Location	Max Pallet Height	Scheduling Hours (in Local Time) / Contact Information
Harrisburg-B, PA 100 Quality Circle, Ste. 100, Harrisburg, PA 17112	72 inches or 1.82 meters	6:00 to 22:30 Monday - Friday <i>All palletized shipments require a delivery appointment which needs to be scheduled by the carrier through Yard Commander. Most carriers already have accounts with this scheduling tool, however, if you have any issues with the system, contact sh-am-us-cevayardcommander@cevalogistics.com</i> (717) 526-1969, ext. 31957 DG-GL-USHB-InboundScheduling@cevalogistics.com

Location	Max Pallet Height	Scheduling Hours (in Local Time) / Contact Information
Fontana, CA 13200 Loop Road Fontana, CA 92337	72 inches or 1.82 meters	8:30 to 16:00 Monday - Friday <i>This location requires a delivery appointment for all TL, LTL, and container shipments. This must be scheduled by the carrier via the Inbound Reservation Portal. Please click here for instructions on using the portal.</i>
Jonestown, PA 80 Micro Drive Jonestown, PA 17038	72 inches or 1.82 meters	8:00 to 14:30 Monday - Friday <i>All palletized shipments require a delivery appointment which needs to be scheduled by the carrier through Yard Commander. Most carriers already have accounts with this scheduling tool, however, if you have any issues with the system, contact sh-am-us-cevayardcommander@cevalogistics.com</i> us-cevayardcommander@cevalogistics.com
Lancaster, PA 700 Indian Springs Dr. Lancaster, PA 17601	50 inches or 1.27 meters*	7:00 to 15:00 Monday - Friday <i>This location requires a delivery appointment for deliveries of 8 or more pallets. Click Here for information to include in your appointment request.</i> Tel: 717-285-6200, ext. 2884 LCOinbound@jaygroup.com * Pallet heights up to 50 inches will be received, but a charge for breakdown to 50 inches will apply.
Millington, TN 3820 Micro Drive Millington, TN 38053	72 inches or 1.82 meters	6:00 to 16:00 Monday - Friday <i>All palletized shipments require a delivery appointment which needs to be scheduled by the carrier through Yard Commander. Most carriers already have accounts with this scheduling tool, however, if you have any issues with the system, contact SH-AM-US-CevaYardCommander@Cevalogistics.</i> DG-RR-AM-MillingtonIBScheduling@cevalogistics.com
New Lenox, IL 2301 Ellis Court Suite B New Lenox, IL 60451	55 inches or 1.39 meters	8:00 to 15:00 Monday - Friday <i>This location requires a delivery appointment for deliveries of 8 or more pallets. Click Here for information to include in your appointment request.</i> NLX_Receiving@impactfs.com

Perth Amboy, NJ
1050 Amboy Avenue
Perth Amboy, NJ 08861

72 inches or
1.822 meters

8:30 to 16:00 | Monday - Friday

This location requires a delivery appointment for all TL, LTL, and container shipments. This must be scheduled by the carrier via the [Inbound Reservation Portal](#). Please [click here](#) for instructions on using the portal.

Piscataway, NJ
1570 S Washington Avenue
Piscataway, NJ 08854

72 inches or
1.822 meters

8:30 to 16:00 | Monday - Friday

This location requires a delivery appointment for all TL, LTL, and container shipments. This must be scheduled by the carrier via the [Inbound Reservation Portal](#). Please [click here](#) for instructions on using the portal.

Rancho Cucamonga, CA
12415 6th Street
Rancho Cucamonga, CA
91739

58 inches or
1.4 meters

6:00 to 14:30 | Monday - Friday

All palletized shipments require a delivery appointment which needs to be scheduled by the carrier through [Yard Commander](#). Most carriers already have accounts with this scheduling tool, however, if you have any issues with the system, contact.

sh-am-us-cevayardcommander@cevalogistics.com.

DL-CLS-Inbound-Scheduling@CEVALogistics.com

DL-USRC-Inbound@CEVALogistics.com

Reno, NV
1381 Capital Blvd
Suite 200
Reno, NV 89502

50 inches or
1.27 meters

7:00 to 15:00 | Monday - Friday

This location requires a delivery appointment for palletized deliveries of 8 or more pallets and all floor loaded containers. [Click Here](#) for information to include in your appointment request.

reno inbound@jaygroup.com

Rialto, CA
1409 South Lilac Ave
Bloomington, CA 92316

57 inches or
1.45 meters

6:00-14:00 | Monday - Friday

This location requires a delivery appointment for deliveries of 8 or more pallets. [Click Here](#) for information to include in your appointment request.

Tel. 909-879-7505 ext.3556

RDC-Receiving@impactfs.com

EMEA

Location	Max Pallet Height	Scheduling Hours (in Local Time) / Contact Information
Daventry, Great Britain Nasmyth Road, Daventry, NN11 8 NF	70 inches or 1.8 meters	7:00 to 13:00 Monday - Friday <i>This location requires a delivery appointment for all pallet deliveries.</i> Click Here for information to include in your appointment request. Tel. +44 1908807863 sh-ne-gb-df_Control_Room@cevalogistics.com
Großbeeren, Germany CEVA Logistics Hall 1 Märkische Allee 4-10 14979 Großbeeren DE	78 inches or 1.98 meters	8:00 to 16:00 Monday - Friday <i>This location requires a delivery appointment for all pallet deliveries.</i> Click Here for information to include in your appointment request. Tel. +49 33701 269 61023 SH-EU-DE-CS-Shipwire@Cevalogistics.com
Waalwijk, Netherlands Industrieweg 98 Door C 5145 PW Waalwijk, The Netherlands	70 inches or 1.8 meters	7:30 to 15:30 Monday - Friday <i>All deliveries over 1 pallet require a delivery appointment. To schedule a delivery, please click here for the ASN notification sheet and be sure to provide a valid ASN # to book appointment.</i> Tel. +31 0416 674 111 Mobile: +31 06 155 875 94 SH-EU-NL-CFS-Preadvice-IND@Cevalogistics.com

Canada

Location	Max Pallet Height	Scheduling Hours (in Local Time) / Contact Information
Halton Hills, Ontario, Canada 6 Cleve Court, Unit #2 Georgetown, ON L7G 0L7 Canada	52 inches or 1.3 meters	6:00 to 14:30 Monday - Friday <i>All LTL/palletized inbound shipments require a delivery appointment which needs to be scheduled by the carrier through Yard Commander. Most carriers already have accounts with this scheduling tool, however, if you have any issues with the system, contact sh-am-ca-cevatqcommerce@cevalogistics.com.</i> Tel. (289) 309-3804 HaltonHillsApptdesk@cevalogistics.com

Asia Pacific

Shenzhen, China

Your inventory is only in a single location in Shenzhen, China, however, there are two paths in order to deliver your product to the facility in Shenzhen, China.

Send your inbound shipments directly to the Shenzhen, China facility if they are:

- All full-container load (FCL) shipments (originating in China or any other country)
- Less-than-container load (LCL), Air & Courier shipments originating in China (if arriving from other countries, please send to the Hong Kong address)*

**Please be advised that air shipments originating in countries other than China will be turned away at the Shenzhen address and must be sent to the Hong Kong address.*

Send your inbound shipments to the Hong Kong facility (for transfer later to the Shenzhen facility) if they are:

- Less-than-container load (LCL), Air & Courier originating in countries other than China (if arriving from China, please send directly to the Shenzhen address)
- Small parcel (low volume) shipments from China*
- All Customer returns*

**Small parcel, courier, and customer returns are not allowed to be shipped to the Shenzhen facility directly, instead, these shipments must be sent to the Hong Kong facility. We offer complimentary transportation service 1-2 times a week depending on volume to the Shenzhen facility. Please contact our customer care team at <https://www.shipwire.com/customer-support/> or reach us by phone at 1-888-SHIPWIRE should you wish to schedule an urgent transfer for a fee.*

Location	Max Pallet Height	Scheduling Hours (in Local Time) / Contact Information
Hong Kong CEVA c/o Galle Logistics DD104, LOT 3719, S.Q, ss1, S.I, RP, Tai San Wai, Yuen Long, NT, Hong Kong	Max Pallet Height of 55 inches or 1.4 meters	9:00 to 18:00 Monday - Friday 9:00 to 13:00 Saturday <i>All deliveries require an appointment. Please reference your ASN# in your appointment request.</i> Contact Edwin Wong / Simon Chan / Ada Wong Tel: +852 2838 3160 edwin.wong@gallelogistics.com simon.chan@gallelogistics.com ada.wong@gallelogistics.com lora.luo@cevalogistics.com
Shenzhen 305, Qianhaiwan Free Trade Port, 53 Linhai Road Nanshan District, Shenzhen, 518054, China	Max Pallet Height of 55 inches or 1.4 meters	8:00 to 12:00 and 13:30 to 17:30 Monday - Friday (Saturday and other times by appointment only) <i>Delivery Appointment: All deliveries require an appointment. Please reference your ASN # in your appointment request.</i> Tel: +86 755 26679184 ext.84926 DG-GL-Transport.CNSZ@cevalogistics.com
Kemps Creek, NSW, Australia 1 Darabarra Avenue Kemps Creek, NSW 2178	55 inches or 1.4 meters	7:00 to 17:00 Monday - Friday <i>This location requires a delivery appointment for all pallet deliveries and deliveries of 15 or more loose cartons. At least 2 business days prior to the required delivery time slot, the supplier, their agent, or transport carrier is required to book a delivery date/time with the Shipwire Timeslot team via email. Please send the delivery request form via email (all fields must be completed), Supplier Packing Slip and ASN number to enable the team to confirm a booking quickly and efficiently. If the scheduled delivery is late by more than 15 minutes, you will need to reschedule the delivery for another date.</i> Tel: +61 (0)455 455 191 sh-apac-au-ShipwireTimeslot.Requests@cevalogistics.com Note on Pallet Shipments: Please be advised that this facility is unable to accept plastic, cardboard/paper-based, broken or LOSCAM and CHEP pallets. All pallets must be plain and follow the Australian standard (1165mm x 1165mm, 150mm in height with front and back locking in boards at least 100mm wide). The preparation of pallet shipments must adhere to our standards: there can be no products overhanging the edge of the pallet, pallets must be properly shrink wrapped (3-4 times around all sides), and the shrink wrap must wrap the product to the pallet to be properly secured. Deliveries that do not meet facility requirements are subject to rejection and/or fines to correct.

Additional info

International Receiving

If you are importing inventory, you need to clear customs and pay taxes and duties on inventory. To satisfy documentation requirements for a received shipment, you must provide the correct Importer of Record and Tax ID information and the receiving must arrive at the warehouse free of customs, duties and tariffs. Failure to meet these requirements may result in inventory being denied and/or additional fees charged.

Importer of Record (Only Required for Importing)

The merchant must be listed as the Merchant of Record, Importer of Record or Owner of Record. Shipwire cannot be listed in these records.

Federal Tax ID (Employer Identification Number)

Please make sure you have a Tax ID for the local jurisdiction you are importing into. We offer several guides to help you establish a Tax ID.

Using Customs Brokers for International Shipping

It is recommended that you work with a customs broker to import inventory to minimize delays. Customs brokers will help you clear customs and meet international importing regulations.

Customs on Imported Goods

For customs and duties on imported goods, you must be the ultimate consignee and take responsibility for merchandise clearing customs. If you are not shipping the merchandise directly to Shipwire, be sure the shipper lists you as being responsible for customs duties. Merchandise we receive must be clear of customs duties in order to qualify for Standard Receiving.

If you have any additional questions on Receiving Requirements, please contact our Customer Success team.



CONTACT US AT [HTTPS://WWW.SHIPWIRE.COM/CUSTOMER-SUPPORT/](https://www.shipwire.com/customer-support/) OR REACH US BY PHONE AT 1-888-SHIPWIRE



Shipwire
A CEVA Logistics Company

version 24.03